

MillLine

TUNG^{RI}**TSHRED**

www.tungaloy.com

Tungaloy Report No. 505-G

TUNGTRI-SHRED

Highly productive roughing cutter with serrated edges





ACCELERATED MACHINING

MillLine

TUNG^{TRI}SHRED
TUNGALOY

TUNG^{FORCE}MILL
ACCELERATED MACHINING



TungTri-Shred combines the advantages of Triangular insert with **chip splitting technology** for rough machining **with long overhang**.

www.tungaloy.com

Long-edge rough milling with small chips effectively prevents chatter

Anti Chatter Design

- Wavy cutting edge shape creates smaller chips reducing chatter.



TUNGTRI SHRED



Conventional

- Triangular insert shape and pocket seating ensures rigid clamping during heavy duty machining.

Intelligent and User friendly design

- Each flute (adjacent pockets in radial direction) in the cutter body is offsetted in Z direction. This positioning ensures that the insert in the adjacent flute removes the crest left by the previous insert. Thus, the surface of machined wall is close to be flat.

- No specific insert positioning required as positioning is done on the cutter.

- All cutting edges of the Inserts are identical.

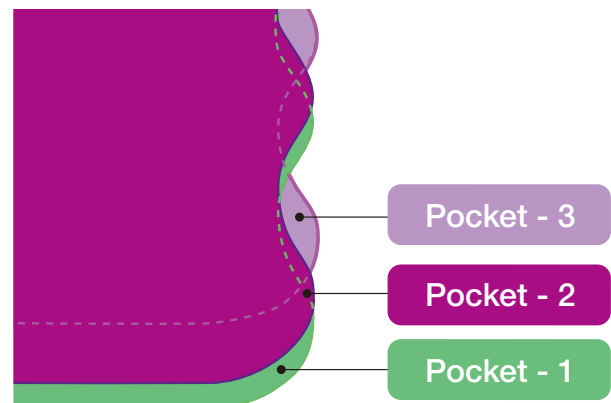

- Insert corner is strengthened to resist corner chip off for the bottom most insert. (the bottom most insert is a single effective corner and withstands the feed equal to feed/rev)

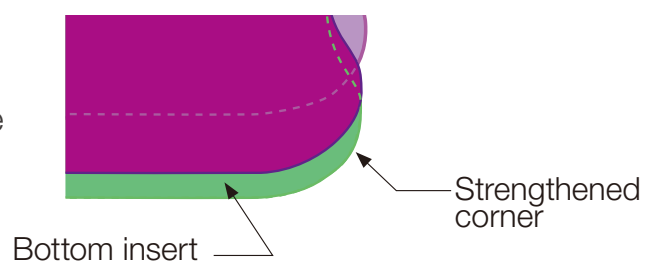

Insert Varieties

2 types of insert fit on the same cutter body providing option for roughing as well as finishing.



TCMT-NMJ

For roughing operation with serrated edges
 - Low cutting force



TCGT-MJ

Suitable for finishing operation or general shoulder square milling.
 - Low cutting force with large rake angle
 - Precise periphery ground insert and unique off-setted positioning of the pocket ensures minimal gap on the machined wall.

Small gap

Large gap

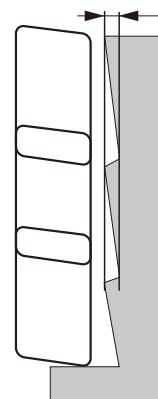
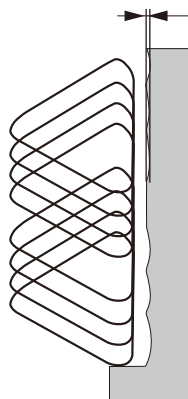

TUNGTRI-SHRED

Conventional, Competitor

CUTTING PERFORMANCE

Comparison of application range

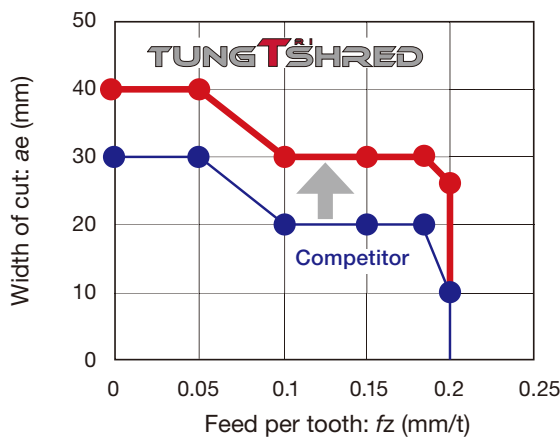

Cutter : LPTC16M080B32.0L076R04 ($\phi D_c = 80$ mm, $z = 4$)
 Insert : TCMT160620PDER-NMJ
 Workpiece material : 42CrMo4 / SCM440H (270HB)
 Cutting speed : $V_c = 100$ m/min
 Depth of cut : $a_p = 70$ mm
 Machine : Vertical M/C (BT50, 37 kw)

TungTri-Shred can be applied for a wider cutting area.

CUTTING PERFORMANCE

Tool life

P Carbon steel with NMJ type

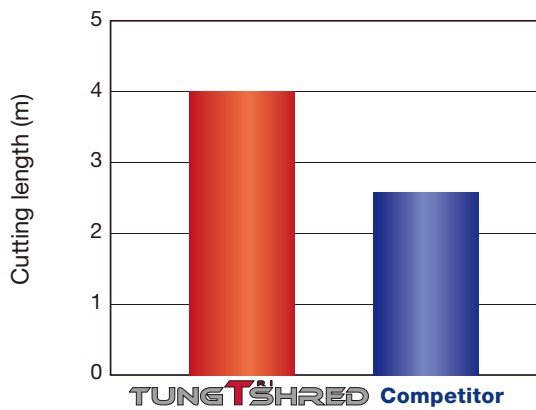

Cutter : LPTC16M080B32.0L076R04 ($\phi D_c = 80$ mm, $z = 4$)
 Insert : TCMT160620PDER-NMJ AH3135
 Workpiece material : S55C / C55 (200HB)
 Cutting speed : $V_c = 150$ m/min
 Feed per tooth : $f_z = 0.18$ mm/t
 Depth of cut : $a_p = 10$ mm
 Width of cut : $a_e = 40$ mm
 Coolant : Dry
 Machine : Vertical M/C, BT50, 30kW
 Machining : Heavy interrupted
 Tool life criteria : Chipping on edge

P Alloy steel with MJ type

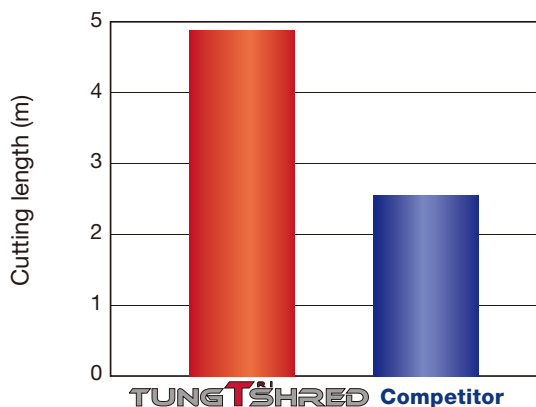

Cutter : LPTC16M080B32.0L076R04 ($\phi D_c = 80$ mm, $z = 4$)
 Insert : TCGT160608PDER-MJ AH3135
 Workpiece material : SCM440 / 42CrMo4 (270HB)
 Cutting speed : $V_c = 150$ m/min
 Feed per tooth : $f_z = 0.15$ mm/t
 Depth of cut : $a_p = 10$ mm
 Width of cut : $a_e = 40$ mm
 Coolant : Dry
 Machine : Vertical M/C, BT50, 30kW
 Machining : Heavy interrupted
 Tool life criteria : Chipping on edge

Square shoulder milling cutters for roughing with shred insert

CUTTER - ROUGHING TYPE - BORE

TungTri-Shred LPTC16

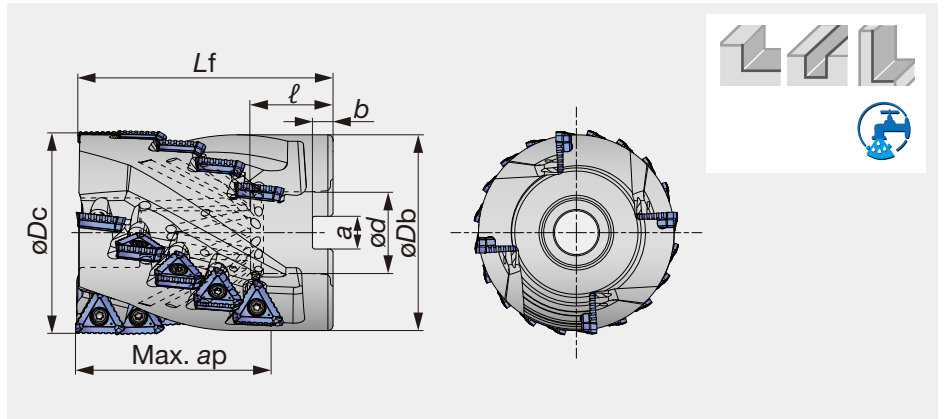

Designation	Max. ap	øDc	Z eff	z	øDb	Lf	ød	l	a	b	Kg	C.bolt	Insert
LPTC16J063B25.4L061R03	61.0	63.00	3	12	59	85.0	25.400	26.00	9.50	6.00	1.25	CAP-CM12X1.75X50	TC*T16
LPTC16M063B27.0L061R03	61.0	63.00	3	12	59	85.0	27.000	22.00	12.40	7.00	1.24	CAP-CM12X1.75X50	TC*T16
LPTC16J080B31.7L076R04	76.0	80.00	4	20	76	100.0	31.750	32.00	12.70	8.00	2.44	CM16X75	TC*T16
LPTC16M080B32.0L076R04	76.0	80.00	4	20	76	100.0	32.000	25.00	14.40	8.00	2.46	CM16X75	TC*T16

SPARE PARTS



Clamping screw	Wrench	
	Torx Bit	Grip
TS 40B100I	BT15S	H-TB2W

Square shoulder milling cutters with shred insert

CUTTER - BORE TYPE

TungTri-Shred TPTC16

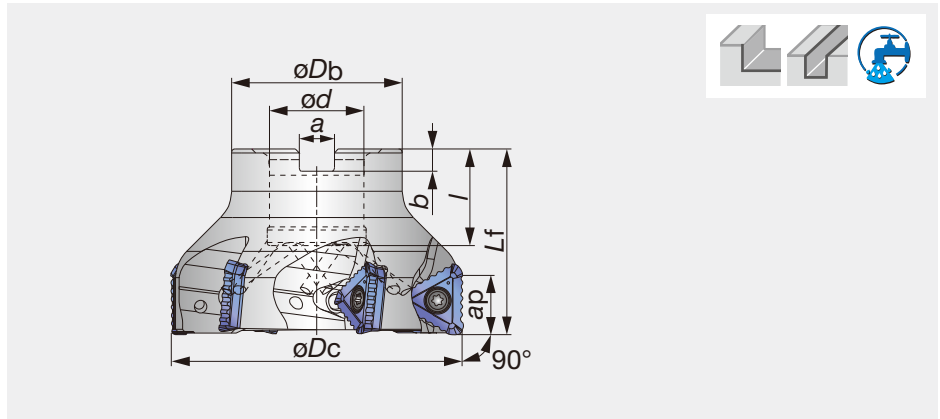

Designation	Max. ap	$\varnothing D_c$	z	$\varnothing D_b$	L_f	$\varnothing d$	ℓ	a	b	Kg	C.bolt	Insert
TPTC16M050B22.0R04	16.0	50.00	4	41	40.0	22.000	20.00	10.40	6.30	0.29	FSHM10-40H	TC*T16
TPTC16M063B22.0R05	16.0	63.00	5	41	40.0	22.000	20.00	10.40	6.30	0.44	CM10X30H	TC*T16
TPTC16J080B25.4R06	16.0	80.00	6	46	50.0	25.400	26.00	9.50	6.00	0.88	CM12X30H	TC*T16
TPTC16M080B27.0R06	16.0	80.00	6	50	50.0	27.000	22.00	12.40	7.00	0.90	CM12X30H	TC*T16
TPTC16J100B31.7R07	16.0	100.00	7	60	50.0	31.750	26.00	9.50	6.00	1.38	TMBA-M16H	TC*T16
TPTC16M100B32.0R07	16.0	100.00	7	60	50.0	32.000	28.50	14.40	8.00	1.35	TMBA-M16H	TC*T16

SPARE PARTS



Clamping screw	Wrench	
	Torx Bit	Grip
TS 40B100I	BT15S	H-TB2W

Square shoulder milling cutters with shred insert

CUTTER - SHANK TYPE

TungTri-Shred EPTC16

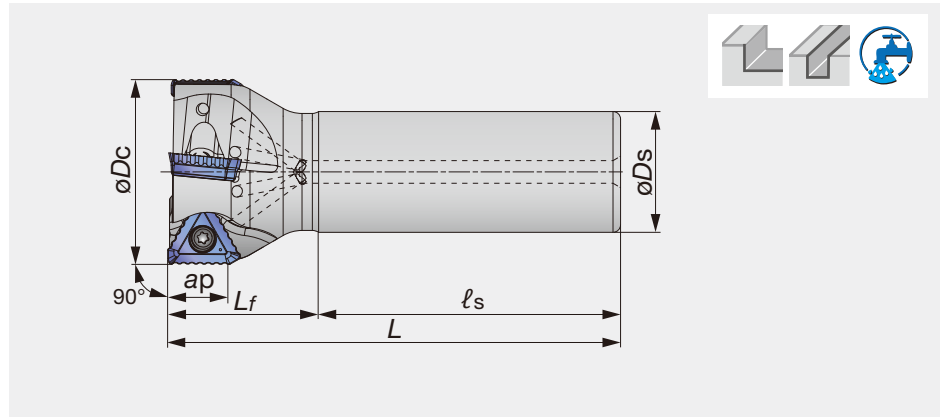

Designation	Max. ap	ϕD_c	z	ϕD_s	l_s	L_f	L	Kg	Insert
EPTC16M050C32.0R04	16.0	50.00	4	32.0	80.0	40.0	120.0	0.80	TC*T16
EPTC16M050C42.0R02L	16.0	50.00	2	42.0	310.0	50.0	360.0	3.80	TC*T16

SPARE PARTS



Clamping screw	Torx Bit	Wrench Grip
TS 40B100I	BT15S	H-TB2W

INSERTS

TCGT-MJ

TCMT-NMJ

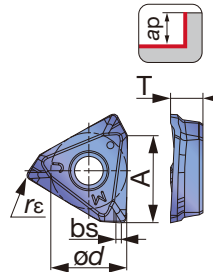

Designation	Max. ap	A	ød	T	rε	bs	AH3135	AH120
TCGT160608PDER-MJ	16	16	13.7	5.8	0.8	1	● ● ● ●	○ ● ●
TCMT160620PDER-NMJ	16	16	13.3	5.8	2	2	● ● ● ●	○ ● ●

● First choice

STANDARD CUTTING CONDITIONS

ISO	Workpiece materials	Hardness	Priority	Grades	Chip-breaker	Cutting speed Vc (m/min)	Feed per tooth fz (mm/t)
P	Low carbon steel (C15, C20, etc.)	- 300 HB	First choice	AH3135	NMJ*	100 - 250	0.08 - 0.15
		- 300 HB	For finishing	AH3135	MJ	100 - 250	0.08 - 0.2
	Carbon steel and alloy steel (S55C / C55, SCM440 / 42CrMo4, etc.)	- 300 HB	First choice	AH3135	NMJ*	100 - 230	0.08 - 0.15
		- 300 HB	For finishing	AH3135	MJ	100 - 230	0.08 - 0.2
Prehardened steel (NAK80, PX5, etc.)	30 - 40 HRC	First choice	AH3135	NMJ*	100 - 180	0.08 - 0.15	
	30 - 40 HRC	For finishing	AH3135	MJ	100 - 180	0.08 - 0.2	
M	Stainless steel (SUS304 / X5CrNi18-9, SUS316 / X5CrNiMo17-12-3, etc.)	-	First choice	AH3135	NMJ*	90 - 200	0.08 - 0.15
		-	For finishing	AH3135	MJ	90 - 200	0.08 - 0.2
K	Grey cast iron (FC250 / 250, FC300 / 300, etc.)	150 - 250 HB	First choice	AH120	NMJ*	140 - 250	0.08 - 0.15
		150 - 250 HB	For finishing	AH120	MJ	140 - 250	0.08 - 0.25
	Ductile cast iron (400-15, FCD600 / 600-3, etc.)	150 - 250 HB	First choice	AH120	NMJ*	140 - 250	0.08 - 0.15
		150 - 250 HB	For finishing	AH120	MJ	140 - 250	0.08 - 0.25
S	Titanium alloys (Ti-6Al-4V, etc.)	-	First choice	AH120	NMJ*	20 - 60	0.08 - 0.15
		-	For finishing	AH120	MJ	20 - 60	0.08 - 0.18
	Heat-resistant alloys (Inconel718, etc.)	-	First choice	AH120	NMJ*	20 - 40	0.08 - 0.13
		-	For finishing	AH120	MJ	20 - 40	0.08 - 0.15

* When you use the NMJ chipbreaker, please set up the feed less than 0.15 mm/t.

PRACTICAL EXAMPLES

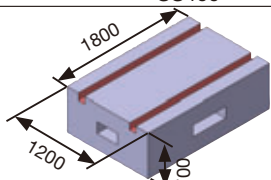
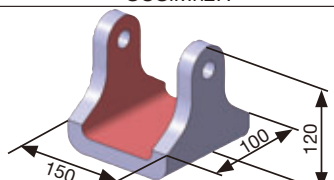
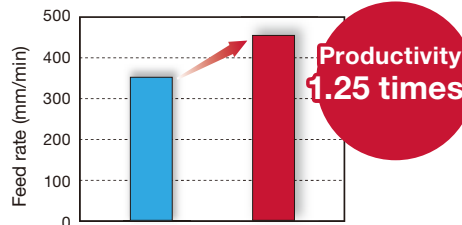
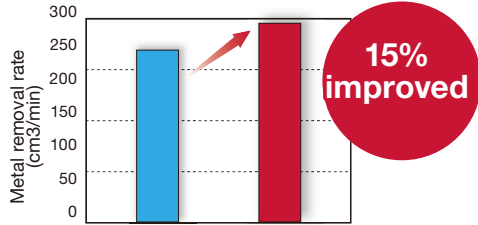
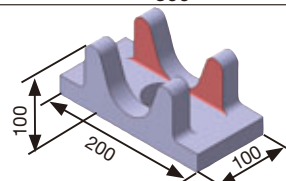
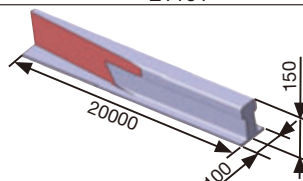
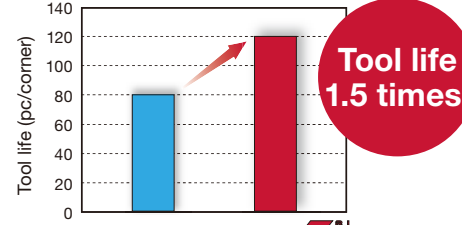
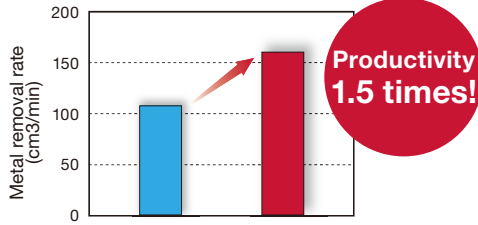
Workpiece type	Machine parts	Bracket	
Holder	LPTC16J063B25.4L061R03 (ø63, z = 3)	LPTC16M080B32.0L076R04 (ø80, z = 4)	
Insert	TCMT160620PDER-NMJ	TCMT160620PDER-NMJ	
Grade	AH3135 SS400	AH3135 SCSiMn2H	
Workpiece material	 P	 P	
Cutting conditions	Cutting speed: Vc (m/min)	150 (Competitor: Vc = 105)	135 (Competitor: Vc = 126)
	Feed per tooth: fz (mm/t)	0.2	0.33 (Competitor: fz = 0.3)
	Feed speed: Vf (m/min)	455	709
	Depth of cut: ap (mm)	50	75
	Width of cut: ae (mm)	10	5
	Method of machining	Shoulder milling	Shoulder milling
	Coolant	Air	Air
Machine	Tower M/C, BT50	Vertical M/C, BT40	
Results	 <p>Productivity 1.25 times!</p> <p>Lower cutting force of TungTri-Shred allows increasing the cutting speed by 25% and eventually achieving high productivity.</p>	 <p>15% improved</p> <p>The cutting force of TungTri-Shred is lower than competitors, allowing productivity improvement of 15%. This reduces customer's process cost.</p>	
Workpiece type	Flange	Rail	
Holder	TPTC16M050B22.0R04 (ø50, z = 4)	LPTC16M080B32.0L076R04 (ø80, z = 4)	
Insert	TCMT160620PDER-NMJ	TCGT160608PDER-MJ	
Grade	AH120 300	AH120 E1101	
Workpiece material	 P	 P	
Cutting conditions	Cutting speed: Vc (m/min)	150	125 (Competitor: Vc = 57)
	Feed per tooth: fz (mm/t)	0.18	0.15
	Feed speed: Vf (m/min)	700	240
	Depth of cut: ap (mm)	2	45
	Width of cut: ae (mm)	10	15
	Method of machining	Shoulder milling	Shoulder milling
	Coolant	Wet	Air
Machine	Horizontal M/C, BT40	Tower M/C, BT50	
Results	 <p>Tool life 1.5 times!</p> <p>Smaller chip size and reduced cutting forces improves tool life by 1.5 times.</p>	 <p>Productivity 1.5 times!</p> <p>Cutting sound and forces were low allowing increase of cutting speed and subsequently improving productivity. Wall surface finish achieved with MJ insert was very good.</p>	

Tungaloy Corporation (Head office)

11-1 Yoshima-Kogyodanchi
Iwaki-city, Fukushima, 970-1144 Japan
Phone: +81-246-36-8501
Fax: +81-246-36-8542
www.tungaloy.co.jp

Tungaloy America, Inc.

3726 N Ventura Drive
Arlington Heights, IL 60004, U.S.A.
Phone: +1-888-554-8394
Fax: +1-888-554-8392
www.tungaloyamerica.com

Tungaloy Canada

432 Elgin St. Unit 3
Brantford, Ontario N3S 7P7, Canada
Phone: +1-519-758-5779
Fax: +1-519-758-5791
www.tungaloy.co.jp/ca

Tungaloy de Mexico S.A.

C Los Arellano 113,
Parque Industrial Siglo XXI
Aguascalientes, AGS, Mexico 20290
Phone: +52-449-929-5410
Fax: +52-449-929-5411
www.tungaloy.co.jp/mx

Tungaloy do Brasil Ltda.

Rua dos Sabias N.104
13280-000 Vinhedo, São Paulo, Brazil
Phone: +55-19-38262757
Fax: +55-19-38262757
www.tungaloy.com/br

Tungaloy Germany GmbH

An der Alten Ziegelei 1
D-40789 Monheim, Germany
Phone: +49-2173-90420-0
Fax: +49-2173-90420-19
www.tungaloy.de

Tungaloy France S.A.S.

ZA Courtaboeuf - Le Rio
1 rue de la Terre de feu
F-91952 Courtaboeuf Cedex, France
Phone: +33-1-6486-4300
Fax: +33-1-6907-7817
www.tungaloy.fr

Tungaloy Italia S.r.l.

Via E. Andolfato 10
I-20126 Milano, Italy
Phone: +39-02-252012-1
Fax: +39-02-252012-65
www.tungaloy.it

Tungaloy Czech s.r.o.

Turanka 115
CZ-627 00 Brno, Czech Republic
Phone: +420-532 123 391
Fax: +420-532 123 392
www.tungaloy.cz

Tungaloy Ibérica S.L.

C/Miquel Servet, 43B, Nau 7
Pol. Ind. Bufalvent
ES-08243 Manresa (BCN), Spain
Phone: +34 93 113 1360
Fax: +34 93 876 2798
www.tungaloy.es

Tungaloy Scandinavia AB

Bultgatan 38
442 40 Kungälv, Sweden
Phone: +46-462119200
Fax: +46-462119207
www.tungaloy.se

Tungaloy Rus, LLC

36-D Harkovsky Lane
308009 Belgorod, Russia
Phone: +7 4722 24 00 07
Fax: +7 4722 24 00 08
www.tungaloy.co.jp/ru

Tungaloy East LLC

Stachek str., h.4, office 2, Ekaterinburg,
620017, Russia
Phone: +7-343-389-13-22
Fax: +7-343-278-94-35
www.tungaloy.co.jp/ru

Tungaloy Polska Sp. z o.o.

ul. Genewska 24
03-963 Warszawa, Poland
Phone: +48-22-617-0890
Fax: +48-22-617-0890
www.tungaloy.co.jp/pl

Tungaloy U.K. Ltd

The Technology Centre,
Wolverhampton Science Park
Glaisher Drive, Wolverhampton
West Midlands WV10 9RU, UK
Phone: +44 121 4000 231
Fax: +44 121 270 9694
www.tungaloy.co.jp/uk
salesinfo@tungaloyuk.co.uk

Tungaloy Hungary Kft

Erzsébet királyné útja 125
H-1142 Budapest, Hungary
Phone: +36 1 781-6846
Fax: +36 1 781-6866
www.tungaloy.co.jp/hu
info@tungaloytools.hu

Tungaloy Turkey

Dudullu, OSB 4. Cad No:4
34776 Umraniye Istanbul, TURKEY
Phone: +90 216 540 04 67
Fax: +90 216 540 04 87
www.tungaloy.com.tr
info@tungaloy.com.tr

Tungaloy Benelux b.v.

Tjalk 70
NL-2411 NZ Bodegraven, Netherlands
Phone: +31 172 630 420
Fax: +31 172 630 429
www.tungaloy-benelux.com

Tungaloy Croatia

Josipa Kozarca 4
10432 Bregana, Croatia
Phone: +385 1 3326 604
Fax: +385 1 3327 683
www.tungaloy.hr

Tungaloy Cutting Tool (Shanghai) Co., Ltd.

Rm No 401 No.88 Zhabei
Jiangchang No.3 Rd
Shanghai 200436, China
Phone: +86-21-3632-1880
Fax: +86-21-3621-1918
www.tungaloy.co.jp/tots

Tungaloy Cutting Tool (Thailand) Co., Ltd.

Interlink tower 4th Fl.
1858/5-7 Bangna-Trad Road
km.5 Bangna, Bangna, Bangkok 10260
Thailand
Phone: +66-2-751-5711
Fax: +66-2-751-5715
www.tungaloy.co.th

Tungaloy Singapore (Pte.), Ltd.

62 Ubi Road 1, #06-11 Oxley BizHub 2
Singapore 408734
Phone: +65-6391-1833
Fax: +65-6299-4557
www.tungaloy.co.jp/tspl

Tungaloy Vietnam

Unit 18, 4th Fl. Saigon Centre Building
65 Le Loi Blvd.
Dist 1, Ho Chi Minh City, Vietnam
Phone: +84-8-3827-0201
Fax: +84-8-3827-0203
www.tungaloy.co.jp/tspl

Tungaloy India Pvt. Ltd.

Indiabulls Finance Centre,
Unit # 902-A, 9th Floor,
Tower 1, Senapati Bapat Marg,
Elphinstone Road (West),
Mumbai -400013, India
Phone: +91-22-6124-8804
Fax: +91-22-6124-8899
www.tungaloy.co.jp/in

Tungaloy Korea Co., Ltd

#1312, Byucksan Digital Valley 5-cha
Beotkkot-ro 244, Geumcheon-gu
153-788 Seoul, Korea
Phone: +82-2-2621-6161
Fax: +82-2-6393-8952
www.tungaloy.co.jp/kr

Tungaloy Malaysia Sdn Bhd

50 K-2, Kelana Mall, Jalan SS6/14
Kelana Jaya, 47301
Petaling Jaya, Selangor Darul Ehsan
Malaysia
Phone: +603-7805-3222
Fax: +603-7804-8563
www.tungaloy.co.jp/my

Tungaloy Australia Pty Ltd

PO Box 2232, Rowville,
Victoria 3178, Australia
Phone: +61-3-9755-8147
Fax: +61-3-9755-6070
www.tungaloy.com.au

PT. Tungaloy Indonesia

Kompleks Grand Wisata Block AA-10 No.3-5
Cibitung
Bekasi 17510, Indonesia
Phone: +62-21-8261-5808
Fax: +62-21-8261-5809
www.tungaloy.co.jp/id



www.tungaloy.com

follow us at:

facebook.com/tungaloyjapan

twitter.com/tungaloyjapan

To see this product in action visit:

Tung-TV

www.youtube.com/tungaloycorporation

Distributed by:



DOWNLOAD
Dr. Carbide
Tungaloy



Available on the
App Store



GET IT ON
Google play



ISO 9001 Certified
QC00J0056
Tungaloy Corporation
18/10/1996

ISO 14001 Certified
EC97J1123
Tungaloy Group
Japan site and Asian
production site
26/11/1997